

CONNECTOR



TERMINAL



A

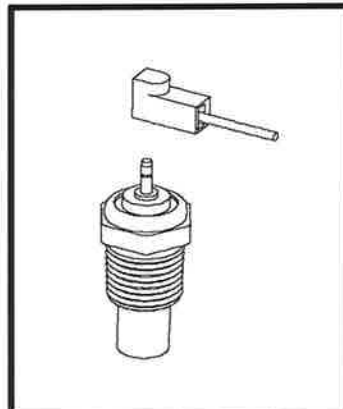

CONNECTOR



TERMINAL



B

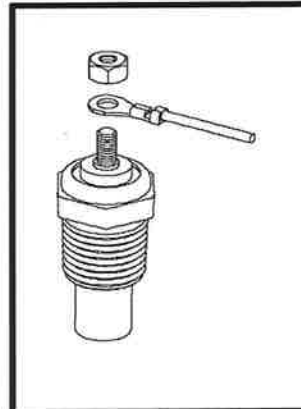

RING
TERMINAL



C

NOTE: SOME AFTERMARKET SENDING UNITS REQUIRE DIFFERENT STYLE CONNECTORS THAN WERE ORIGINALLY USED. THESE INSTRUCTIONS SHOW THE ORIGINAL APPLICATIONS FOR TEMPERATURE SENDING UNITS ONLY. APPLICATIONS SHOWN ARE FOR CAMARO. THIS KIT ALSO APPLIES TO MANY OTHER GM VEHICLES.

STEP 1:

DETERMINE WHICH CONNECTOR AND TERMINAL APPLIES TO YOUR TEMPERATURE SENDING UNIT AND CRIMP TERMINAL ONTO WIRE.

NOTE: TERMINAL MUST BE SOLDERED AFTER CRIMPING.

CAUTION: DO NOT ALLOW SOLDER TO FLOW INTO MATING SURFACES OF ANY OF THE FEMALE TERMINALS.

STEP 2:

INSTALL APPROPRIATE CONNECTOR ONTO TERMINAL.

STEP 3:

INSERT WIRE THROUGH LOOM.

STEP 4:

SPLICE WIRE TO ORIGINAL TEMPERATURE SENDING UNIT WIRE.

YEAR	MODEL	APPLICATION	TERMINAL/CONNECTOR
1967	CAMARO	8 WITH GAUGES	A
1967	CAMARO	8 & 6 WITHOUT GAUGES	B
1968	CAMARO	8 WITH GAUGES	B
1968	CAMARO	8 & 6 WITHOUT GAUGES	A
1969-74	CAMARO	8 WITH GAUGES	C
1969	CAMARO	WITHOUT GAUGES	B
1969	CAMARO	6 WITHOUT GAUGES	A
1970-73	CAMARO	8 & 6 WITHOUT GAUGES	USE ORIGINAL CONNECTOR
1974	CAMARO	8 & 6 WITHOUT GAUGES	USE ORIGINAL CONNECTOR
1975-79	CAMARO	ALL	A

M&H Electric Fabricators, Inc.
AUTOMOTIVE WIRING SYSTEMS

13537 Alondra Blvd. Santa Fe Springs, CA 90670
Phone (562) 926-9552 Fax (562) 926-9572

**TEMPERATURE PIGTAIL KIT
INSTRUCTION SHEET**

92964777