



**Read This First !**

### Installation Guidelines

- Please take a few minutes and review the following before installing your new harness.
1. Place the new harness next to the old harness and compare the following.
    - a. The color and length of wires.
    - b. The type and size of each connector and terminal.
    - c. The position of each wire in the various connectors.
    - d. The type & position of clips, clamps & conduit coverings (when applicable).
- Everything should match exactly. If not, please contact our technical support line at (562) 926-9552 before attempting installation of your new harness.
2. All of our harnesses are manufactured to O.E.M. specifications. From time to time there may be slight variations from the original specifications due to revisions made by the original equipment manufacturer.

3. Do not remove the bar coded-item number label from the new harness, until the new harness has been installed and your complete electrical system has tested OK.

4. When removing the old harness from the car, remember to mark where the original wires were connected. This will simplify the installation of the new harness. If you have any questions regarding the proper installation of your new harness, call our technical support line for installation tips and assistance.

5. Note that some of our Engine Harnesses & Forward Lamp Harnesses utilize a special di-electric grease as original. The grease is smothered inside the bulkhead connector that mounts to the firewall. Do not remove this grease, it is a corrosion inhibitor. Do not allow the grease to come in contact with your clothing, as it will stain.

### Technical Questions ?

*Call us, we want you to be 100% satisfied !*

Technical Support Line



(562) 926-9552

Monday - Friday 8:00 a.m. to 3:30 p.m.  
Pacific Standard Time  
C I P W K P D M H I D

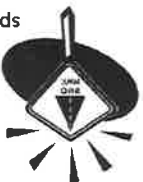

Visit our world wide web site to see answers to FAQ's (Frequently Asked Questions). Feel free to e-mail us with any comments or suggestions regarding our products, service or technical support.

Web Address:  
[www.wiringharness.com](http://www.wiringharness.com)

E-Mail Address:  
[sparky@wiringharness.com](mailto:sparky@wiringharness.com)

## ONE YEAR LIMITED WARRANTY

M&H Electric Fabricators, Inc. warrants the enclosed product to be free of defects in materials and workmanship for a period of one (1) year from the date of original purchase by the end user.

M&H Electric Fabricators, Inc. will repair or replace the enclosed product in the event of a manufacturing defect as follows:

**Parts:** Repair or replacement in exchange for defective parts returned to our facility for one (1) year after the date of original purchase.

**Labor:** Repair or replacement of defective product returned to our facility for one (1) year after the date of original purchase.

This warranty does not cover postage, freight or delivery fees for sending the product to and from our service facility.

Warranty service can be obtained during the warranty period by bringing or shipping the product to:



**13537 Alondra Blvd. Santa Fe Springs, CA 90670**

A purchase receipt or other proof of date of original end user purchase will be required before warranty service can be rendered. This warranty covers normal consumer use and does not cover damage which occurs in shipment or failure which results from alteration, accident, misuse, abuse, neglect, installation or improper maintenance. Under any circumstances, the liability of the manufacturer shall be limited to the original cost of the product(s) paid by the end user and the manufacturer shall not be liable for any consequential or incidental damages which occur as a result of the use of any of our product(s). This limit on liability may vary in your state and you may have additional rights and/or remedies depending on the state in which you live.



The enclosed product is warranted to fit and operate properly in the specific applications for which it is intended. Do not cut, modify, alter, add or remove tape or conduit without consulting M&H Electric Fabricators, Inc.

If the product is tampered with in any way, all warranties are void.

If you experience any difficulties with the installation or the performance of any of our products, do not attempt any modifications without first contacting our technical support department at (562) 926-9552.

Specifications and design subject to possible modification without notice, due to improvements.

**D**

DISTR BUTABLE

THIS DRAWING AND DESIGN HEREON  
 CONSTITUTES A PROPRIETARY DESIGN  
 OF M&H ELECTRIC FABRICATORS, INC.  
 AND IS NOT TO BE DUPLICATED OR  
 REPRODUCED WITHOUT AUTHORITY OF  
 M&H ELECTRIC FABRICATORS, INC.

## REVISIONS

DATE	REV.	DESCRIPTION	APPR. BY
01-31-22	B	UPDATED FOR CLARITY AND RELEASED AS REV B	309

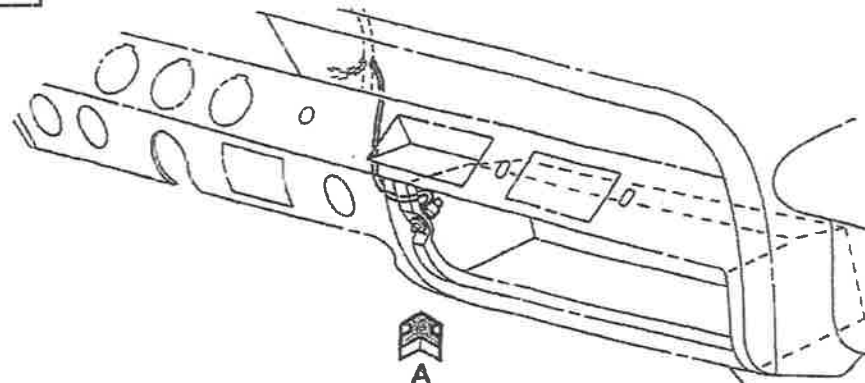

COMPT. ASM.

PANEL - INSTRUMENT CONSOLE

Route wire thru hole in glove box  
 area. Terminal assembles to switch  
 with hook point to rear of car.  
 Terminal must be assembled to switch  
 before bulb can be properly installed.

ORANGE

NOTE Routes between  
 Console & Compt. Asm.

NOTE Insert terminal  
 into receptacle.

VIEW A

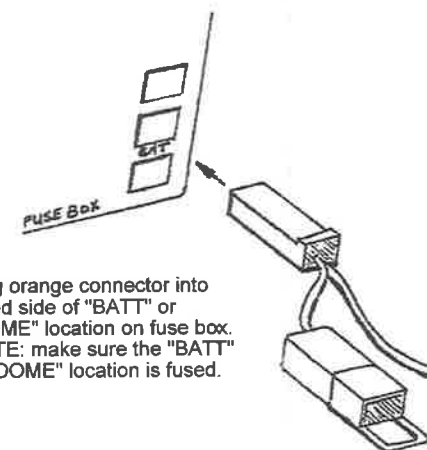

Plug orange connector into  
 fused side of "BATT" or  
 "DOME" location on fuse box.  
 NOTE: make sure the "BATT"  
 or "DOME" location is fused.

**M&H ELECTRIC FABRICATORS, INC**  
**AUTOMOTIVE WIRING SYSTEMS**

(562) 926-9552 www.wiringharness.com

DATE: 01-31-22	REFERENCE NO. M&H #18000	SHEET NO. 1 OF 2
-------------------	-----------------------------	---------------------

TITLE

INSTRUCTION SHEET

PART NO.

92963842